



GVISION Desktop Monitor

MA15BX

**15" Medical Desktop Monitor
with Optional Touchscreen**



The MA15BX is GVision's 15" medical monitor for hospital applications. Designed for medical use, GVISION monitors with optional touchscreen can be easily integrated into a multitude of solutions for healthcare applications such as nursing stations, computer-aided therapy, electronic medical record keeping, paperless charting, patient self-check-in / registration or point-of-information installations. GVISION medical monitors are fully certified with UL 60601. Touch technology can be customized for your projects.



- Customizable video inputs
- UL 60601 certified

For more information please contact

1-888-651-9688 | www.GVISION-USA.com

Where Versatility Meets Flexibility



PARAMETER		MA15BX SPECIFICATION
LCD Display		15" TFT active matrix panel
Pixel Pitch		0.297 (H) x 0.297 (V) mm
Max. Resolution		XGA 1024 x 768
Contrast Ratio		700:1 (Typ.) <small>w/o sensor or glass</small>
Brightness		250 cd/m ² (Typ.) <small>w/o sensor or glass</small>
Response Time (Tr+Tf)		8 ms (Typ.)
Display Color		16.2M
Effective Display Area		304.1 (H) x 228.1 (V) mm
Viewing Angle (CR≥10)		140°(H) x 130°(V) (Typ.) <small>w/o sensor or glass</small>
Lamp Life (hr) / Backlight		35,000 (Typ.) / CCFL
Stand Base		Tilt down : -5°, Tilt up : +90°
Input Signals		Analog, Digital
Signal Connector	Analog Digital	D-Sub15 pin (VGA) DVI-D
Scan Frequency		60 ~ 75 Hz
Audio System		1W per channel
Touch Panel		5-wire Resistive
Touch Interface		RS-232 or USB A type
Power		Universal Power Adapter Input AC 100 ~ 240V, 50 ~ 60 Hz Output DC 12V / 4.2A, 50W
Operating	Temperature	0°C ~ 40°C (32°F ~ 104°F)
	Humidity	10% ~ 90% (no condensation)
	Altitude	To 10,000 feet
Storage	Temperature	-20°C ~ 60°C (-4°F ~ 140°F)
	Humidity	10% ~ 90% (no condensation)
Dimensions (WxHxD)		351.0 x 314.5 x 140.0 mm
Carton Dimensions (WxHxD)		438.0 x 460.0 x 214.0 mm
Weight (Net)		4.5 kg
Certification		CE/FCC UL60601 3rd edition
Standard Pallet Loading (by sea)		40 units (1070 [L] x 880 [W] x 1960 [H] mm)
Standard Pallet Loading (by air)		30 units (1070 [L] x 880 [W] x 1500 [H] mm)

FEATURES

- High contrast color TFT LCD display supports resolution up to 1024 x 768
- Compatible with VGA, IBM and VESA signal standards (resolution/timing auto-detected)
- Compatible with non-standard signals (on request)
- Supports DDC 1/2B for Plug & Play compatibility
- Advanced OSD control for picture quality adjustment
- Rugged all-metal fully enclosed chassis
- VESA standard mounting
- RoHS/WEEE Compliance
- Integrated stereo speakers

OPTIONS

- Anti-Glare / Anti-Reflective tempered glass
- Sunlight Readable
- IP54 waterproof & dustproof sealed front bezel
- Touch sensor technologies: resistive, surface capacitive
- Video Signal input
 - Signal Connector: RCA / S-Video
 - NTSC / PAL / SECAM video

I / O PORTS

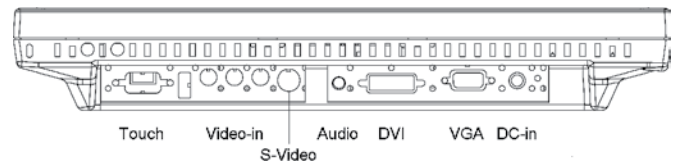

* Specifications are subject to change without notice.

MECHANICAL DRAWING

Unit : mm

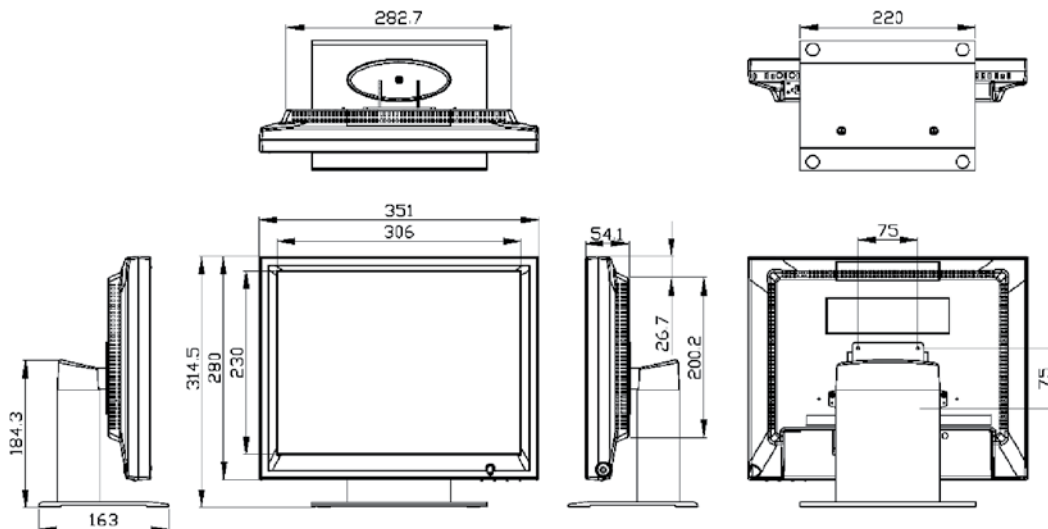

GVISION Inc. USA
20532 Crescent Bay Drive, Suite 104
Lake Forest, CA 92630

